

YS-1905 Bronze Swing Check Valve • Spec Sheet



FEATURES & BENEFITS

- Bronze Swing Check Valve
- 200 WOG Non-Shock
- 150 WSP
- Horizontal Pattern
- Threaded Cap
- Threaded Ends Conform to ANSI Standards B2.1 NPT
- Valves are Tested in Accordance w/MSS-SP-82

Applications: Firefighting Commercial, Light Industrial for Water, Oil, Gas and Steam

DIMENSIONS

Size	Part #	H	L
1/2"	530T03	38	52.5
3/4"	530T04	40.5	59.5
1"	530T05	43	65.5
1-1/4"	530T06	47	80
1-1/2"	530T07	55	88.5
2"	530T08	69	106.5
2-1/2"	530T09	78	132
3"	530T10	100	147
4"	530T11	110	175

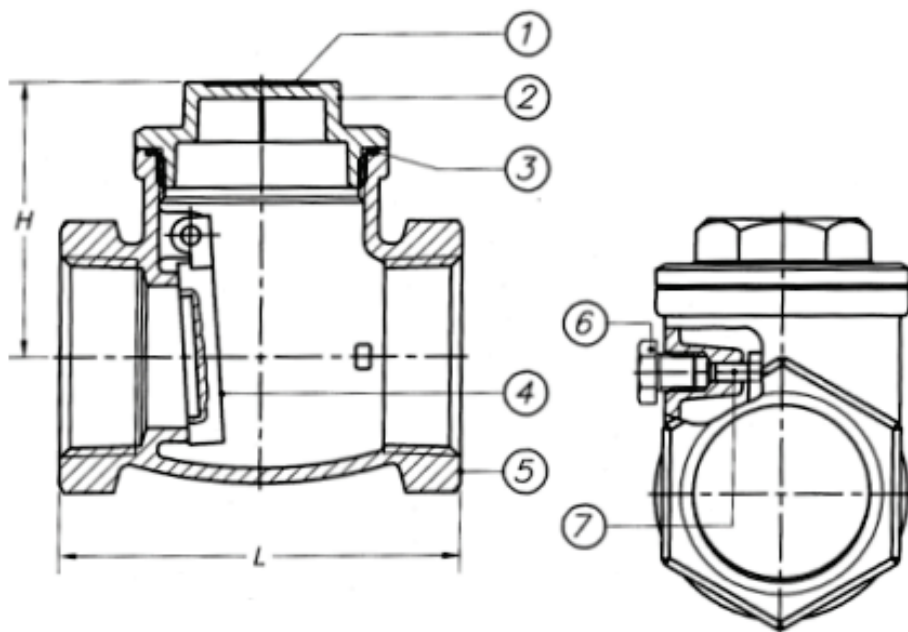

MATERIAL SPECIFICATIONS

No.	Part	Material
1	Name Plate	Aluminum A1100
2	Cap	Bronze B62 C83600
3	Packing	Fibre "H"
4	Disc	Bronze B62 C83600
5	Body	Bronze B62 C836001
6	Bolt	Brass B16 C36000
7	Pin	Brass B124 C37700